

### Packing List

No.	Item	Model/Type	Quantity	Remarks
1	Main Device	MiniC-100	1	
2	Power Line		1	
3	QC PASS Card		1	
4	Screw	M3*10	2	with washer
5	Allen Wrench	M3	1	
6	Block Handle	M4*30	1	
7	Performance Test		1	
8	Manual		1	
QC:		Date:		

## Mini Dry Bath MiniC-100

### Manual



#### **Hangzhou Yooning Instrument Co., Ltd.**

Address: 4 floor, #6 Building, No.3 Shengang Road,  
Yuhang District, Hangzhou, China

Customer Service: +86-571-86907383 / 87613616

Website: [www.yooning.com](http://www.yooning.com)

**Hangzhou Yooning Instrument Co., Ltd.**

## General Information

Thank you for purchasing our Products: MiniC-100.  
This Manual for users contains function and operation of the Instrument. In order to use the instrument properly, please read this manual carefully.

Please check the instrument and accessories with the packing list at the first time you open the instrument packing case.

## Appendix 1: MiniC-100 Wiring Diagram

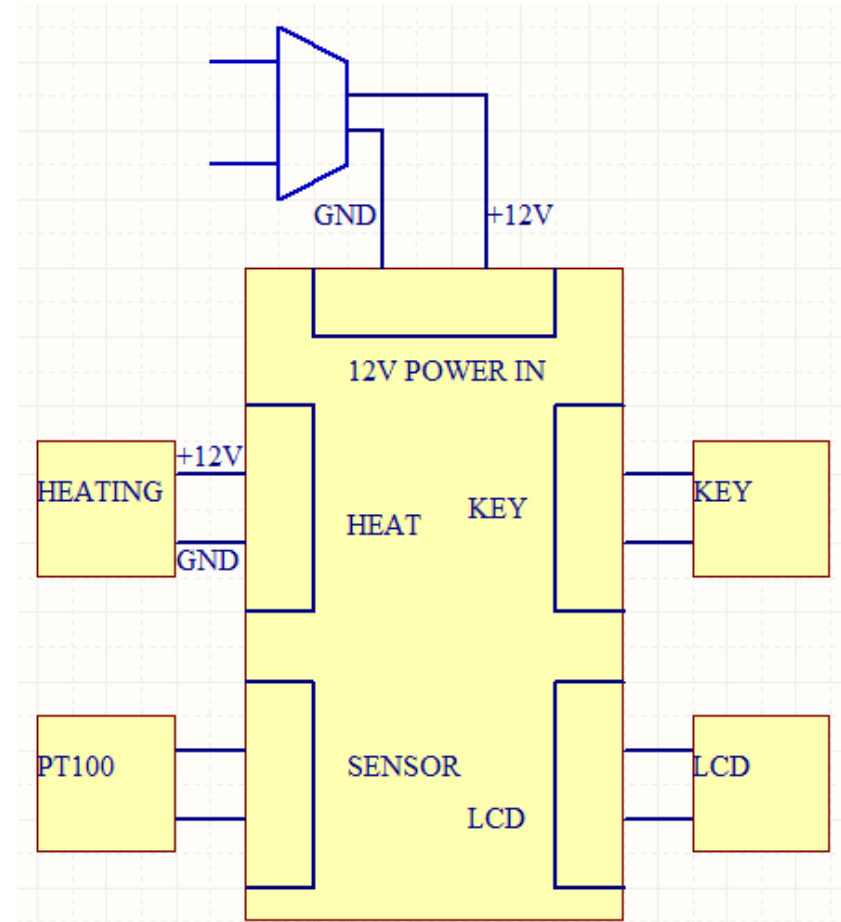

## 5. The maintenance of the Instrument



The well in the block should be cleaned by the cloth stained with alcohol to assure good heat translation between the block and the test tube and no pollution. If there are smutches on the Instrument, clean them with cloth.



Power off when cleaning the Instrument.  
When cleaning the well, don't drop the cleaning liquid in the well.  
Corrosive cleaning liquid is strongly prohibited.

## 6. Troubles and Shootings

Troubles	Causes	Shootings
No signals on the display	No power Broken switch Broken CU	Check the connection of power; Exchange the switch; Contact to the Seller.
“OPEN” in the display with the alarm	Temperature Sensor Open Circuit	Contact to the Seller.
“SHORT” in the display with the alarm	Temperature Sensor Short Circuit	Contact to the Seller.
The module not heating	Broken heater	Contact to the Seller.
The buttons not working	Broken Buttons	Contact to the Seller.

## Contents

1 Introduction .....	1
1.1 Instrument Integrity .....	1
1.2 The Structure .....	2
1.3 Operation Guide .....	3
2. The Parameters .....	4
3. Safety and Warnings .....	5
4. Operation Guide.....	6
4.1 The Functions of the Keys .....	6
4.2 Program setting.....	6
4.3 The Program .....	6
4.4 Temperature Setting .....	6
4.5 Time Setting .....	6
4.6 Time Units .....	7
4.7 Start/Stop .....	7
4.8 Temperature Calibration .....	8
4.9 The System .....	10
5. The Maintenance of the Instrument .....	11
6. Troubles and Shootings .....	11
Appendix 1 .....	12
Packing List.....	12

## **1. Introduction**

MiniC-100 Dry Bath is a micro-processor controlled heating block with heater (heating types) technology. It adapts onboard use, smart, light and convenient for movement. It's widely used in preservation and reaction of the samples, DNA amplification and pre-denaturation of electrophoresis, serum coagulation, etc. Read this Manual carefully before using it.

### **1.1 Instrument Integrity**

Mini Dry Bath	1
Voltage	1
Manual	1
Certificate	1

**Note:** Press “Prog” to cancel the current temperature calibration during the operation, and the system will default to the last calibration. Please don't press the button ▲ and ▼ at the same time.

Be careful! In order to ensure the accuracy, the instrument must keep constant temperature for 20min after reaching any calibration .

### **4.9 The System**

Turn on the instrument, press Prog for about 2s and then enter the system.

#### **4.9.1 APF**

Press Start to set, press ▼ and ▲ to choose “ENABLE” and “DISABLE” and set APF. The instrument will automatically heat up.

Close APF, the instrument will not automatically heat up. Press Start and the instrument can heat up.

**APF ENABLE**

**APF DISABLE**

**Note:** The system default APF is enabled, and the user can manually configure it as needed.

Press Start/Stop, the instrument saves the current settings and exits the system.

**4.8.3** Press the button ▲ and ▼ at the same time to set the temperature. Please refer to following Fig. It automatically warms up from 40°C. \* flickers regularly. When the temperature reaches 40°C, \* stops flickering. Five minutes later, the buzzer begins to sound regularly.

**4.8.4** Read the figure on the thermometer after 15min. If it is 39.8°C, then press ▲ or ▼ to modify the temperature, and press Start to correct.

**4.8.5** It automatically warms up from 70°C. \* flickers regularly. When the temperature reaches 70°C, \* stops flickering. Five minutes later, the buzzer begins to sound regularly.

**4.8.6** Read the figure on the thermometer after 15min. If it is 69.8°C, then press ▲ or ▼ to modify the temperature, and press Start to correct.

**4.8.7** It automatically warms up from 100°C. \* flickers regularly. When the temperature reaches 100°C, \* stops flickering. Five minutes later, the buzzer begins to sound regularly.

**4.8.8** Read the figure on the thermometer after 15min. If it is 99.8°C, then press ▲ or ▼ to modify the temperature, and press Start to correct.

**4.8.9** Return the Start page and correct the temperature again.

**P1A 99.5 XX**

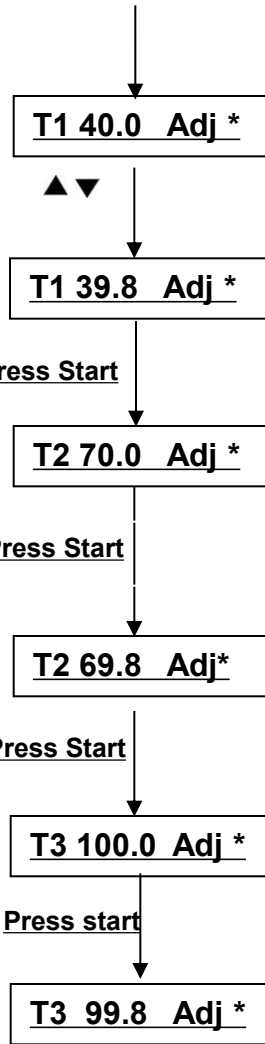

## 1.2 The Structure

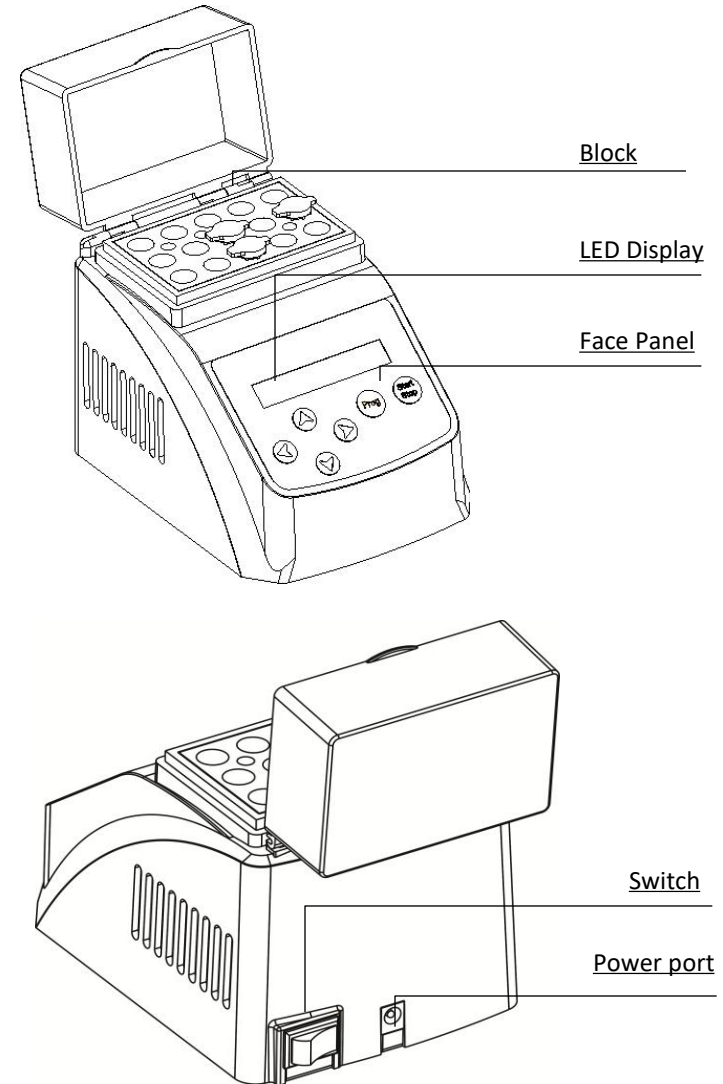

**Note:** After the temperature is calibrated, the measured temperature of the module is consistent with the displayed temperature.

### 1.3 Operation Guide

**1.3.1** Place the instrument on a stable workbench.

**1.3.2** Insert the power cord into the power socket on the back of the instrument as shown in the figure, and connect the other end of the external power cord to the power grid. The grid voltage is between AC 100V ~ 240V.

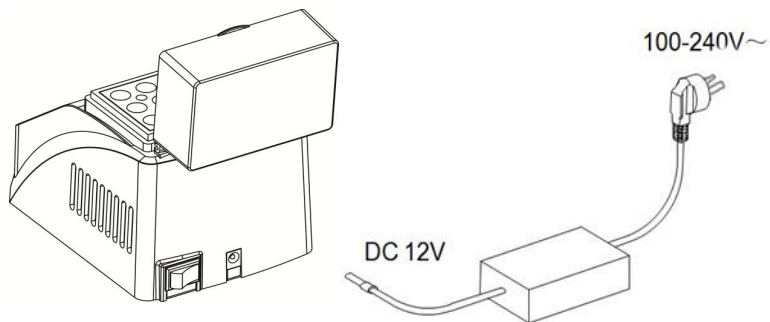

**1.3.3** Open the switch, the instrument will automatically heats up to the set temperature for 5min.

**1.3.4** Put the tubes into the instrument and then close the cover.

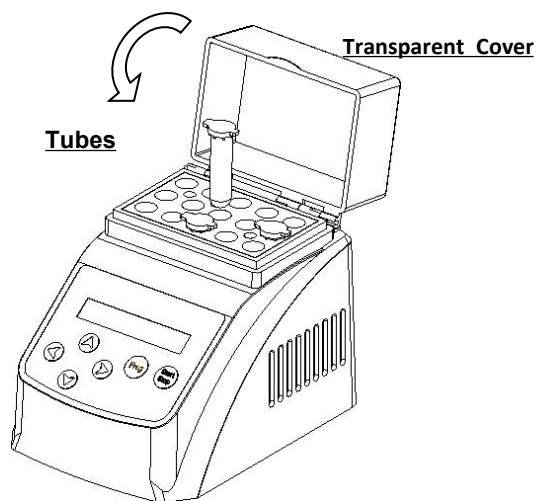

### 4.8 Temperature Calibration

The temperature has been calibrated by the manufacturer and can be re-calibrated following the steps specified below.

**Note: Please do not attempt to re-calibrate the temperature unless necessary. Please place the instrument at room temperature below 35°C for calibration.**

**Steps as the following:**

**4.8.1** After the startup of the instrument, it enters waiting interface.

**4.8.2** Inject olefin oil into one of the cone-shaped wells, and then put a thermometer into this well (Make sure the precision of the thermometer should be within 0.1°C and the temperature ball should be absolutely immersed into the cone-shaped well). Heat insulation material is needed on the block to separate it from the circumstance. Seeing from Fig a.

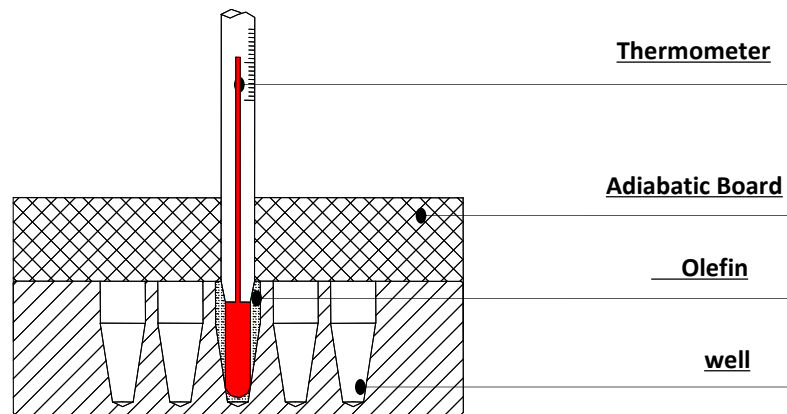

Fig a

**Note:** The time is 00:00, the instrument starts to operate.

#### 4.6 Time Units

Press Prog, press ◀ and ▶ to set the time units, then press ▲ or ▼ to set the time units: s, m, h.

When "OFF" is display, it can stop operating.

#### 4.7 Start/Stop

**4.7.1** The instrument begins to operate, the last temperature and time is displayed.

**4.7.2** Press Start/Stop, the blocks start to heat up. WAIT and the current temperature is display.

When it reaches the setting temperature, "OK" will replace "WAIT" and the instrument start countdown . Time is over, the instrument start Phase II, "WAIT" and the current temperature is display.

When it reaches the setting temperature, "OK" will replace "WAIT" and the instrument start countdown.

**4.7.3** Time is over and the buzzer alarms. The instrument will stop. Finished and the temperature is display. Then press the buttons to return the main page.

**Note:** Time is countdown, press Start/Stop to suspend the instrument. Suspend the time, press the Start/Stop for 2s to stop the instrument.

⏏  
P2A 45 00S  
⏏

⏏  
P2A 45 030M  
⏏

First  
P2A 45 WAIT

P2A 50 04M OK

Second  
P2B 55 WAIT

P2B 60 05M OK

Finished T:60

## 2. The Parameters

Parameter	Type	MiniC-100 (Cooling)
Temperature control range (Temperature setting range)		RT-25°C ~ 100°C (Max.-10°C~ 100°C)
Heating time (20°C to 100°C)		≤15min
Temperature Accuracy discrepancy		± 0.3°C
Temperature Control Discrepancy @40 °C		± 0.3°C
Temperature control Discrepancy @100 °C		± 0.3°C
Temperature Accuracy Display		0.1°C
Time Setting		1-99h, 1-99m, 1-99s, 0(Infinite)
Max. Temperature		100°C
Max. Power		120W
Cooling Time (Cooling down by 25°C from room temperature)		≤30min
weight		≤1.5kg
Dimension(L×W×H) (mm)		153×110×137

### 3. Safety & Warnings



Indoor used instrument.



Read the Manual carefully before operation. Only trained personnel can operate the instrument.



The users should not open or repair the Instrument by himself, which will result in losing the warranty.



The instrument should be placed in a room with low humidity, less dust, and away from water sources, direct sunlight and strong light sources. The room should be well ventilated, and away from heating, fire and other heat sources, and interference of corrosive gas or strong magnetic field. Do not put the instrument in a wet or dusty place.



Mains switch is on the back of the device, push "I" to power on the device, and push "O" to power off the device.



The power is DC12V



Power off the instrument after using. Pull off the power cord after the instrument is not in use for a long time.

### 4. Operation Guide

#### 4.1 The Functions of the Keys

**Start/Stop**-----Control the instrument to operation

**Prog** ----- Set the system

**▲▼** ----- Set the temperature and the time

**◀** ----- Move left to set the figures

**▶** ----- rotation direction

#### 4.2 Program Setting

There are 9 programs, P1 to P9 including 3 steps each program. For example, there are P2A, P2B and P2C of program 2. The user can choose "OFF" to stop in the last two steps. The instrument starts again, it can heat up to the temperature of the first step set last time.

The user can set the any program manually. For example, if P2A and P2C operate, press Start and P2A and P2C can run.

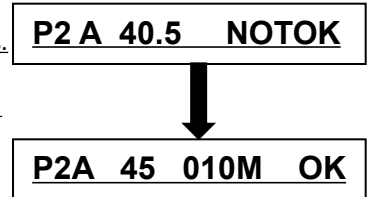

#### 4.3 The Program

Press **Prog.** and the program number flashes. Press **▲** and **▼** to choose the program.

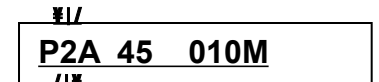

#### 4.4 Setting Temperature

Press **Prog.** and press **◀** and **▶** to set the temperature. Then press **▲** and **▼** to set the figures.

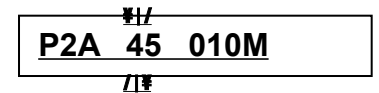

#### 4.5 Setting Time

Press **Prog.** and press **◀** and **▶** to set the time. Then press **▲** and **▼** to set the time.

