

Directions for Use

Vivaflow 50 | 50R | 200



Contents

Vivaflow 50	3
Single Module	3
Linked Modules	4
Diafiltration Desalting	5
Concentration	6
Recovery	6
System Components	7
Technical Specifications	7
Performance Characteristics	8
Ordering Information	9
Chemical Compatibility	10
Vivaflow 50R and Vivaflow 200	11
Operation of Single Module	11
Operation of Two Modules	12 – 13
Diafiltration Desalting	14
Concentration	14
Recovery	14
Technical Specifications	15
Cleaning	16
Storage	16
Performance Characteristics	17 – 18
Ordering Information	19 – 20
Chemical Compatibility	21

Vivaflow 50

Designed for **single use** only. Anything else constitutes improper use.

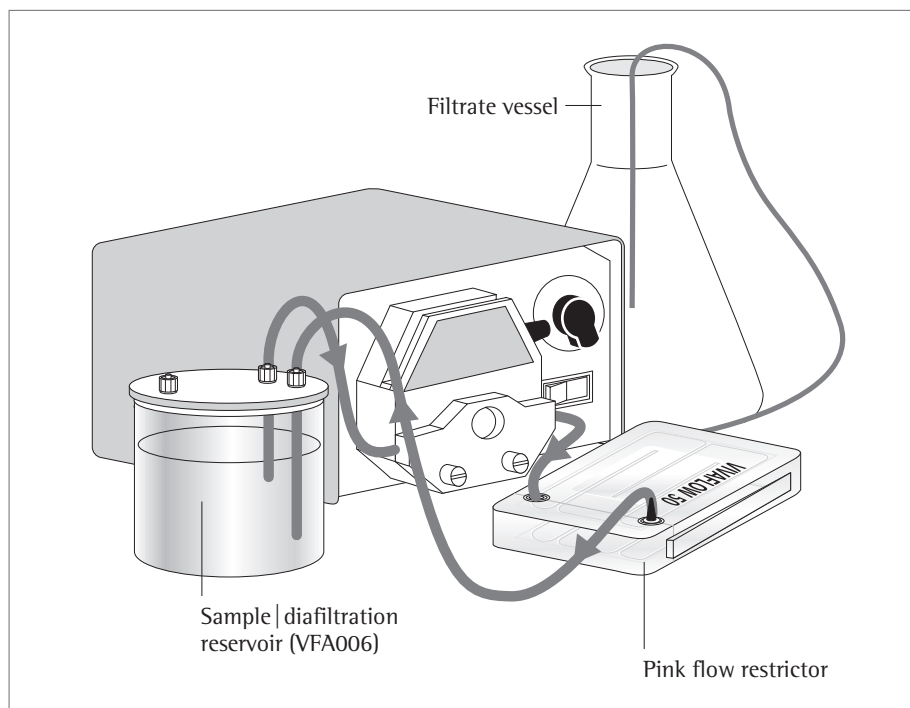

Diagram 1: Vivaflow 50 set up

Single module

1. Set up the system as illustrated in Diagram 1. Note the positioning of the flow restrictor on the return line.
2. Vivaflow membranes contain trace amounts of glycerine and sodium azide. To remove these chemicals and to check the security of the tube connections, it is recommended to rinse the module, and to test the system at full pressure before introducing the sample.
3. Place 500 ml deionised water in a suitable reservoir. The Vivaflow sample | diafiltration reservoir (prod. no. VFA006) is recommended.
4. Pump liquid through the system to purge any air pockets. The recirculation rate should be in the range 200–400 ml/min, and suitable flow should exit the filtrate line. If used, the pressure indicator (prod. no. VFA020), should read approximately 2.5 bar.
5. Allow 400 ml to pass into the filtrate vessel. Check for any leakage at tubing connection points. Drain the system and empty or replace the filtrate vessel, (see recovery section). The system is now ready for use.

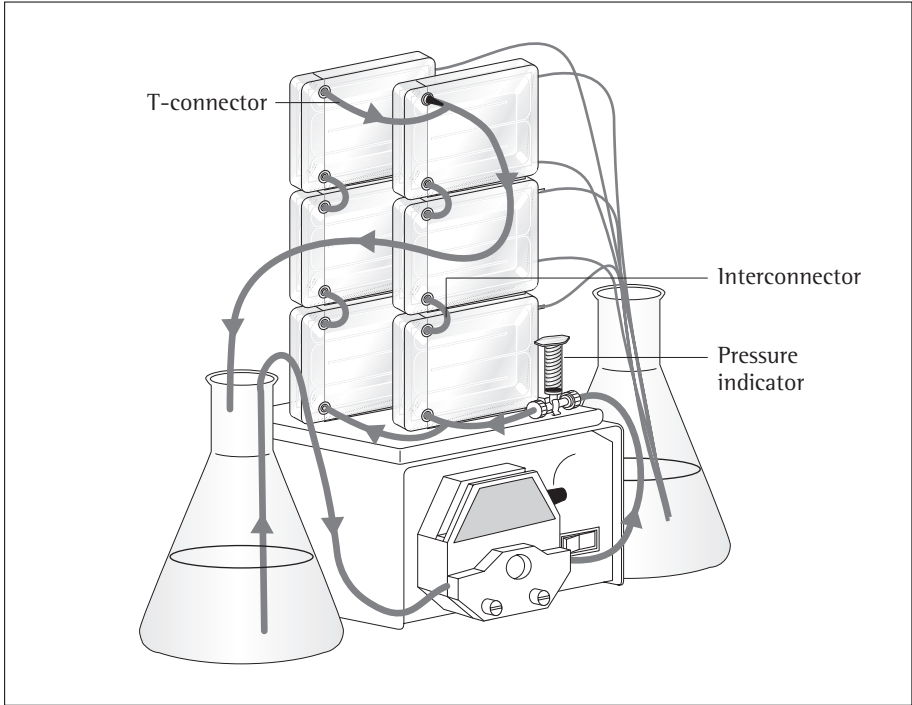

Diagram 2: Setting up multiple Vivaflow 50 cassettes

Linked modules

1. Set up the system as illustrated in Diagram 2. Link the required number of modules by sliding the tongue and groove edges together. Note the positioning of the flow restrictor on the return line.
2. Use series interconnectors, (prod. no. VFA031), to connect a single row of modules. Detailed ordering information for system components to be found of page 7, Diagram 4.
3. In addition, use T-connectors, (prod. no. VFA030), to connect two rows of modules in parallel.
4. The flow path of the system can be configured to suit the membrane | sample combination. Most solutions are better suited by modules connected in parallel. Very low viscosity solutions favour modules connected only in series. Rinse the system as detailed under single module operation.

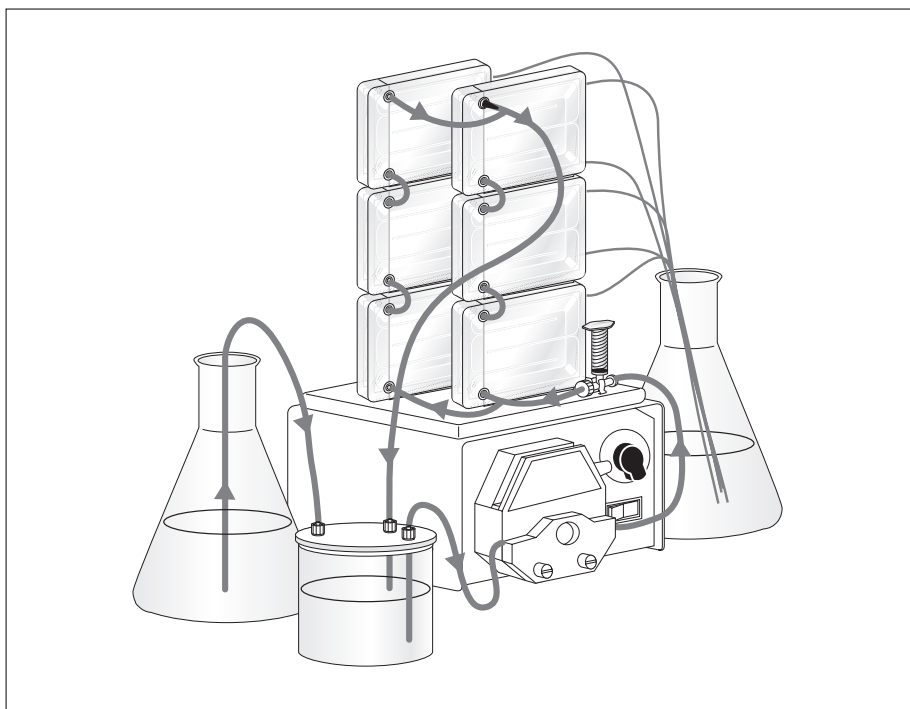

Diagram 3: Buffer exchange | diafiltration with Vivaflow 50

Diafiltration | Desalting

1. Set up the system as illustrated in Diagram 3 for linked modules. If only one module is required, connect it in place of the linked modules.
2. Rinse the system as detailed previously.
3. Either place the solution to be purified in the 500 ml sample | diafiltration reservoir (prod. no. VFA006), or concentrate a larger volume to 500 ml or less so that it is fully contained in the 500 ml reservoir. Ensure the reservoir lid is firmly closed.
4. Fill a large feed reservoir with exchange solvent and pump sample through the system as for concentration.
5. As the volume in the 500 ml reservoir decreases, the vacuum created draws exchange solvent through the feed line from the larger reservoir. Over 99% solvent exchange can be accomplished with an exchange volume approximately 5 times the volume of the sample.

Concentration

1. Fill the feed reservoir with sample solution. When initial volumes larger than 500 ml are required, place 500 ml in the sample | diafiltration reservoir, the remaining volume in another suitable container and connect the vessels as detailed in the diafiltration section. Alternatively, use a larger container for the entire sample volume and immerse the feed and return lines directly into the liquid.
2. Pump liquid through the system. The recirculation rate should be in the range 200–400 ml/min, and suitable flow should exit the filtrate line. If used, the pressure indicator, (prod. no. VFA020), should read approximately 2.5 bar.
3. Concentrate the sample to the desired volume.

⚠ Warning: Do not run the same section of tubing through the pump head for longer than six hours, over use of tubing will result in significant pressure drop and ultimately, failure.

4. When the desired volume has been reached, reduce the recirculation rate to 20–40 ml/min and recirculate the concentrated sample for 1–2 minutes to maximise recovery.

Recovery

1. Disconnect the feed line from the lid of the 500 ml reservoir or when using a different container, remove the feed line from the sample.
2. Pump residual system volume back into the reservoir | container. (When parallel modules are used with viscous solutions, ensure that all modules are empty by pinching the tubing between each of the stacks of modules in turn).
3. For a more complete sample recovery rinse approximately 5–10 ml per module of water or sample buffer through the system, and recover as before.

System Components

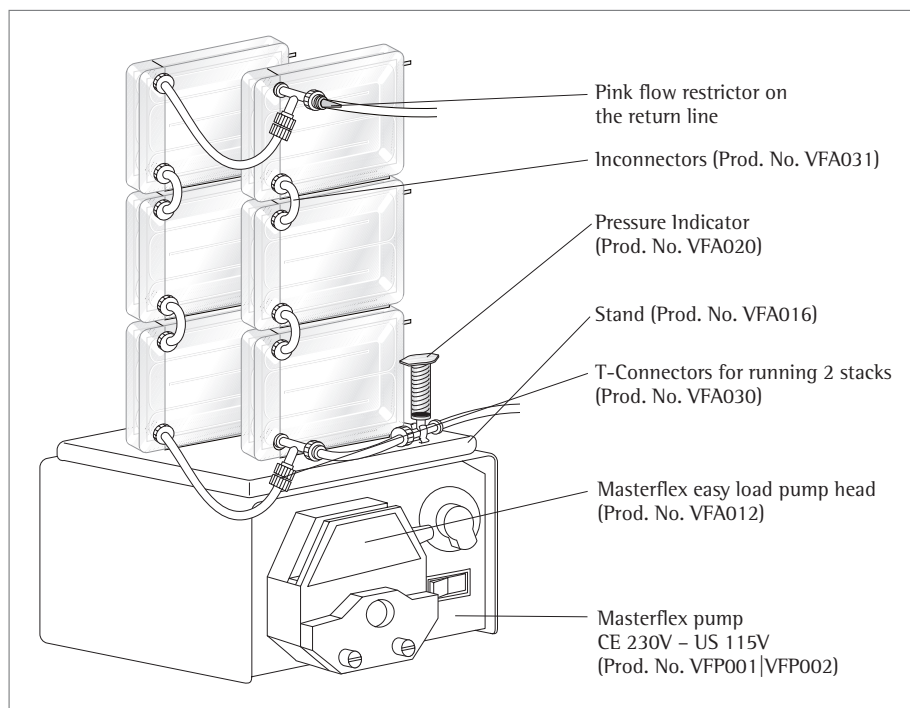

Diagram 4: System components for setting up multiple Vivaflow 50 units

Table 1: Technical Specifications

Dimensions

Overall L H W	107 84 25 mm
Channel W H	15 mm 0.3 mm
Active membrane area	50 cm ²
Hold up volume (module)	1.5 ml
Min recirculation volume	< 10 ml
Non recoverable hold-up	< 0.5 ml

Operating Conditions

Pump flow	200–400 ml/min
Maximum pressure	3 bar (45 psi)
Maximum temperature	60 °C

Materials of Construction

Main housing	Polycarbonate
Flow channel	TPX (PMP)
Membrane support	TPX (PMP)
Seals and O rings	Silicone
Pressure indicator	Polypropylene, SS Spring,
Flow restrictor	Polypropylene
Fittings	Nylon
Tubing	PVC (medical grade)

Table 2: Performance characteristics

	Time to concentrate up to 20x (min.) at 3 bar inlet pressure, 20°C			
	Single Device	Three Devices	Solute Recovery %	
	250 ml Start Vol. min.	1 L Start Vol. min.	Direct	10 ml rinse
BSA 1.0 mg/ml (66,000 MW)				
5,000 MWCO PES	34	49	96%	> 99%
10,000 MWCO PES	22	32	94%	> 99%
30,000 MWCO PES	22	32	92%	99%
50,000 MWCO PES	20	29	92%	98%
γ Globulins 1.0 mg/ml				
100,000 MWCO PES	43	62	92%	98%
100,000 MWCO RC	40	58	92%	98%
100,000 MWCO Hydrosart	40	58	92%	98%
Yeast 1.0 mg/ml (S.Cerevisiae)				
0.2 μm PES	33	47	92%	98%

Ordering Information

Vivaflow 50 include filtrate tube, size 16 peristaltic tubing, flow restrictor and fittings and 1 × Series Interconnector	Pack Size	Prod. No.
3,000 MWCO (PES)	2	VF05P9
5,000 MWCO (PES)	2	VF05P1
10,000 MWCO (PES)	2	VF05P0
30,000 MWCO (PES)	2	VF05P2
50,000 MWCO (PES)	2	VF05P3
100,000 MWCO (PES)	2	VF05P4
0.2 µm (PES)	2	VF05P7
100,000 MWCO (RC)	2	VF05C4

Vivaflow 50 complete system comprises

Pump (240 V), easy load pump head (size 16), tubing, 500 ml sample diafiltration reservoir, module stand, pressure indicator, T connectors, series interconnectors	1	VFS502
Pump (115 V), easy load pump head (size 16), tubing, 500 ml sample diafiltration reservoir, module stand, pressure indicator, T connectors, series interconnectors	1	VFS504

Vivaflow 50 PVC tubing and fittings

Size 16 PVC pump tubing (3 metres, 3.2 × 1.6 mm)	VFA004
Flow restrictor set (2 × 0.4, 0.6, 0.8 mm)	VFA009
T connectors for running 2 stacks (2 pieces)	VFA030
Series interconnectors (6 pieces)	VFA031
Female luer fittings (10 pieces)	VFA032
VF50 tubing kit (2 × 1 m size 16 PVC tubing with inlets fittings, 2 × 50 cm size 16 PVC tubing with 0.6 mm flow restrictors, 1 × series inlet connections)	VFA034
Flow restrictor 0.6 mm (6 pieces)	VFA035

Vivaflow 50 accessories

Masterflex economy drive variable speed peristaltic pump (230 V)	VFP001
Masterflex economy drive variable speed peristaltic pump (115 V)	VFP002
500 ml sample and or diafiltration reservoir	VFA006
Masterflex easy load pump head – size 15	VFA013
Masterflex easy load pump head – size 16	VFA012
Vivaflow 50 stand	VFA016
Pressure indicator (1–3 bar)	VFA020

**Table 3: Chemical Compatibility
for the Vivaflow 50**

Solution	PES	RC	Solution	PES	RC
Acetic acid (25%)	OK	OK	Peracetic acid (0.2%)	OK	OK
Acetone	NO	NO	Phenol (1%)	OK	?
Ammonium hydroxide (5%)	OK	OK	Phosphate Buffer (1 M)	OK	OK
Ammonium sulfate sat.	OK	OK	Pyridine	NO	NO
DMEM	OK	OK	RPMI-1640	OK	OK
Ethanol (70%)	OK	OK	Sodium azide	OK	OK
Ethyl acetate	NO	NO	Sodium deoxycholate (5%)	OK	OK
Formaldehyde (30%)	OK	OK	Sodium hydroxide (1 M)	NO	NO
Formic acid (5%)	OK	OK	Sodium hydroxide (0.1 M)	NO	NO
Guanidine HCl (6 M)	OK	OK	Sodium hypochlorite (0.02%)	?	?
Hydrocarbons, Aromatic	NO	?	Sodium nitrate	NO	NO
Hydrocarbons, Chlorinated	NO	NO	Sulfamic acid (5%)	OK	NO
Hydrochloric acid (1 M)	OK	NO	Surfactants (0.1%)	OK	OK
Isopropanol	NO	NO	Toluene	NO	NO
Lactic acid (5%)	OK	OK	Trichloroacetic acid (10%)	NO	?
Mercaptoethanol (10 mM)	OK	OK	Trifluoroacetic acid (10%)	OK	NO
Methanol (60%)	OK	OK	Urea (8 M)	OK	OK
n-Butanol (70%)	OK	OK			

OK = Acceptable

? = Questionable

NO = Not recommended

Vivaflow 50R and Vivaflow 200

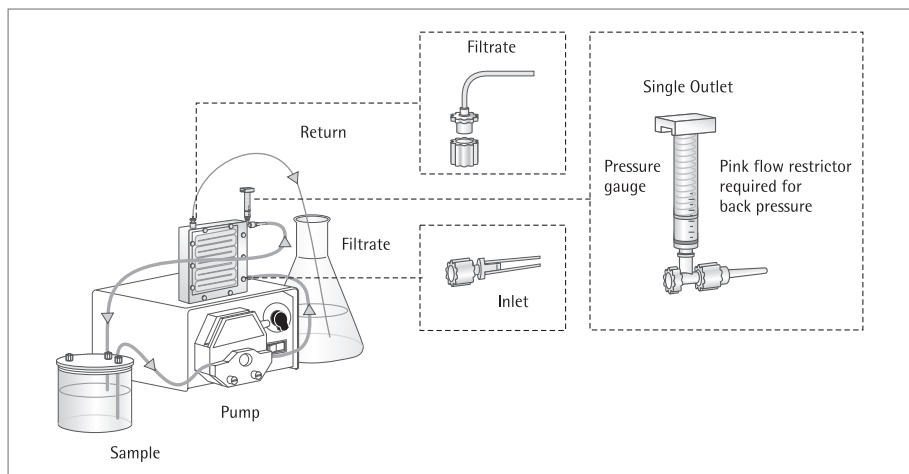

Diagram 5: Vivaflow 50R and Vivaflow 200 set up

Operation Single Vivaflow 50R or Vivaflow 200 Modules

Assembly and rinsing single module

1. Set up the system as illustrated above in Diagram 5.. Note the positioning of the flow restrictor on the return line. A set of flow restrictors of different gauges (Product No. VFA009), is available for use with solutions of unusually high or low viscosity.
2. Vivaflow membranes contain trace amounts of glycerine and sodium azide. To remove these chemicals and to check the security of the tube connections, it is recommended to rinse the module, and to test the system at full pressure before introducing the sample.
3. Place 500 ml deionised water in a suitable reservoir.
4. Pump liquid through the system to purge any air pockets. The recirculation rate should be 200–400 ml/min, and suitable flow should exit the filtrate line. If used, the pressure indicator should read approximately 2.5 bar.
5. Allow 400 ml to pass into the filtrate vessel. Check for any leakage at tubing connection points.
6. Drain the system and empty or replace the filtrate vessel (see Recovery section). The system is now ready for use.

⚠ **Warning:** Ensure Luer connections are secure before operation.

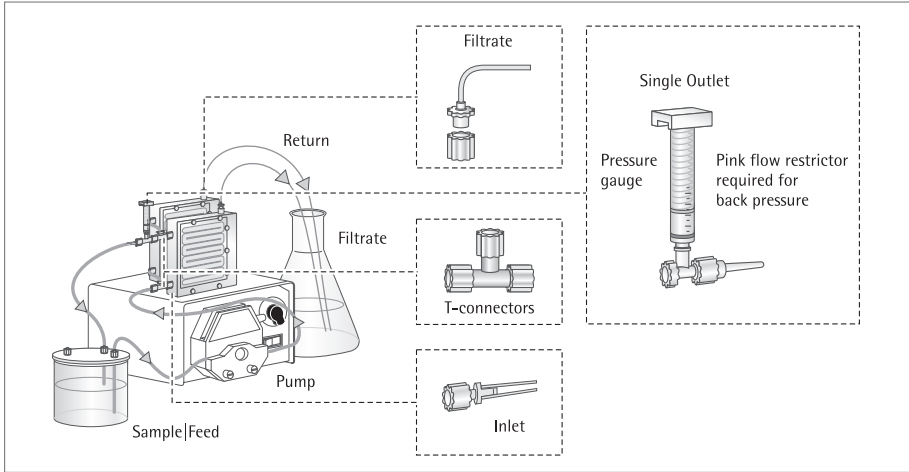

Diagram 6: Setting up two Vivaflow 50R units

Operating two Vivaflow 50R or two Vivaflow 200 Modules

Assembly and rinsing two modules

1. Set up the Vivaflow 50R system as illustrated in Diagram 6 and the Vivaflow 200 System as illustrated in Diagram 7 system as illustrated above.

⚠ Warning: Ensure Luer connections are secure before operation.

2. Vivaflow 50R:

Use two T-connectors (VFA030) to connect to the inlets of both Vivaflow 50R modules.

Vivaflow 200:

Use the Y-connector, (VFA005) to connect to the inlets of both Vivaflow 200 modules.

The size 15 tubing connected to the Y-connector is the inlet tubing for the pump. Use a size 15 pump head.

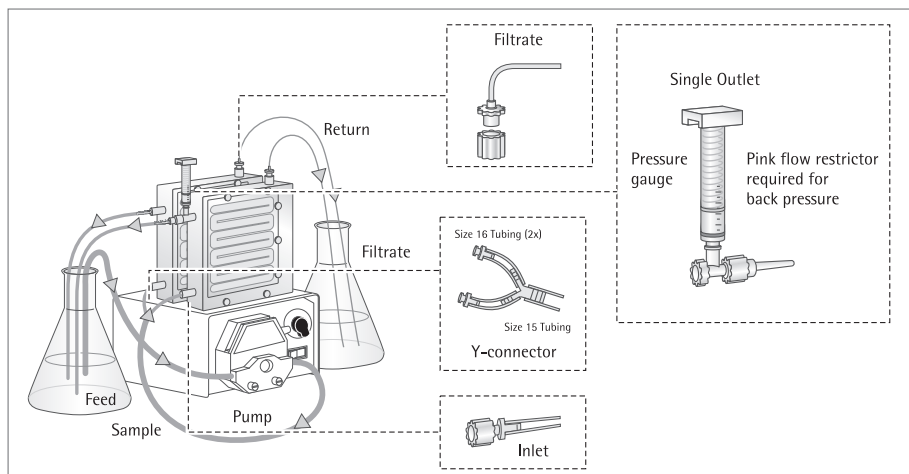

Diagram 7: Setting up two Vivaflow 200 units

3. Note the positioning of a flow restrictor on the return line from each Vivaflow 200 module. Vivaflow membranes contain trace amounts of glycerine and sodium azide. To remove these chemicals and to check the security of the tube connections, it is recommended to rinse the module, and to test the system at full pressure before introducing the sample.
4. Place 1 litre of deionised water in a suitable reservoir.
5. Pump liquid through the system to purge any air pockets. The recirculation rate should be 500–900 ml/min, and suitable flow should exit the filtrate line. If used, the pressure indicator should read approximately 2.5 bar.
6. Allow 800 ml to pass into the filtrate vessel. Check for any leakage at tubing connection points.
7. Drain the system and empty or replace the filtrate vessel (see Recovery section). The system is now ready for use.



Diagramm 8: Buffer exchange | Desalting with Vivaflow 50R and Vivaflow 200

Diafiltration | Desalting

1. Set up the system as illustrated in Diagram 8.
2. Rinse the system as detailed previously.
3. Place the solution to be purified in a suitable diafiltration reservoir. For volumes up to 500 ml the Vivaflow 500 ml sample | diafiltration reservoir (VFA006), is recommended. Ensure the lid is firmly closed.
4. Fill the large feed reservoir with exchange solvent and pump sample through the system as for concentration.
5. As liquid passes through the membrane, the vacuum created in the diafiltration reservoir draws in exchange solvent through the feed line from the large reservoir. Over 99% solvent exchange can be accomplished with an exchange volume of approximately 5 times the sample volume.

Concentration

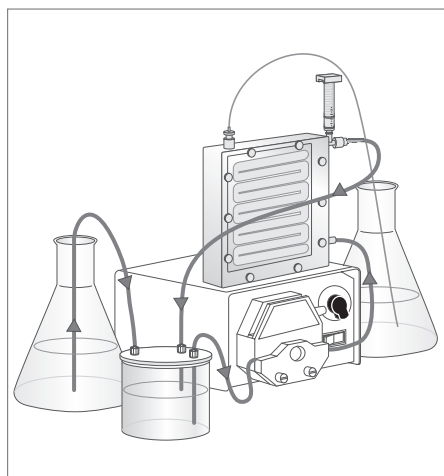
1. Fill the feed reservoir with sample solution.
2. Pump liquid through the system. The recirculation rate should be 200–400 ml/min, (500–900 ml/min for two modules), and suitable flow should exit the filtrate line. If used, the pressure indicator should read approximately 2.5 bar.

⚠ Warning: Do not run the same section of tubing through the pump-head for longer than 6 hours, overuse of tubing will result in significant pressure drop and ultimately, failure.

3. Concentrate the sample.
4. When nearing the desired volume, reduce the recirculation rate to 20–40 ml/min and recirculate the concentrated sample for 1–2 minutes to increase sample recovery.

Recovery

1. Remove the feed line from the sample.
2. Pump residual system volume back into the reservoir | container.
3. For a more complete recovery, rinse 25–50 ml of water or sample buffer through the system, and recover as before.

Table 4: Technical specifications Vivaflow 50R and Vivaflow 200

Dimensions	Vivaflow 50 R	Vivaflow 200
Overall L H W	100 100 24 mm	126 138 38 mm
Channel W H	7.5 0.4 mm	10 mm 0.4 mm
Active membrane area	50 cm ²	200 cm ²
Hold up volume (module)	1.7 ml	5.3 ml
Min. recirculation volume	10 ml	< 20 ml
Non recoverable hold-up	< 0.5 ml	< 1 ml
Materials of construction	Vivaflow 50R and Vivaflow 200	
Main housing	Acrylic	
Flow channel	Acrylic	
Membrane support	Polypropylene	
Seals and O rings	Silicone	
Pressure indicator	Polypropylene, SS spring	
Flow restrictor	Polypropylene	
Fittings	Nylon	
Tubing	PVC (medical grade)	
Operating conditions	Vivaflow 50R and Vivaflow 200	
Pump flow	200–400 ml/min	
Maximum pressure	4 bar (60 psi) Pressure drop across inlet outlet 0.5 bar (7 psi)	
Maximum temperature	60 °C	

Cleaning and storage information only for Vivaflow 50R and Vivaflow 200

Cleaning

Vivaflow 50R and 200 modules may be used several times if cleaning and storage instructions are followed.

1. Flush the system with 200 ml of deionised water with the filtrate going to waste.
2. Place the feed, return and filtrate lines in a suitable container for the cleaning solution.
3. Prepare cleaning solutions suitable for the membrane.
 1. Polyethersulfone membranes:
250 ml of 0.5 mM NaOCl in 0.5 M NaOH
 - II. Hydrosart membranes: 250 ml of
0.5 M NaOH
4. Recirculate at 50–100 ml/min for 30–40 minutes.
5. Drain the system and recirculate 250 ml of deionised water through the system for 5–10 minutes.
6. Drain and discard rinse solution and flush with a further 500 ml of deionised water with the filtrate going to waste. The system is now ready for further use.

Storage

To store Vivaflow 50R and Vivaflow 200 after cleaning, fill module with deionised water and 10% ethanol. Seal inlet, outlet and filtrate ports and refrigerate at approximately 4°C.

Table 5: Performance characteristics Vivaflow 50R

	Time to concentrate up to 20x (min) at 3.0 bar inlet 2.5 bar outlet pressure, 20°C			
	start volume	Average flux	Recovery %	
	250 ml	ml/min	Direct	25 ml rinse
Lysozyme 0.25 mg/ml (14,000 MW)				
5,000 MWCO Hydrosart	70	3.4	96%	98%
10,000 MWCO Hydrosart	23	10.3	94%	96%
BSA 1.0 mg/ml (66,000 MW)				
10,000 MWCO Hydrosart	24	9.9	98%	> 99%
30,000 MWCO Hydrosart	15	15.8	97%	> 99%
γ Globulins 1.0 mg/ml (150,000 MW)				
100,000 MWCO Hydrosart	46	5.2	97%	> 99%
Start volume 1 litre (one Vivaflow 50R at 3 bar) 10,000 MWCO Hydrosart				
BSA 1.0 mg/ml	95	10.0	98%	> 99%
Start volume 1 litre (two Vivaflow 50R in parallel at 3 bar) 10,000 MWCO Hydrosart				
BSA 1.0 mg/ml	48	19.8	98%	> 99%

Table 6: Performance characteristics Vivaflow 200

	Time to concentrate up to 20x (min.) at 3 bar inlet pressure, 20°C			
	start volume	Average flux	Recovery %	
	1 litre	ml/min	Direct	25 ml rinse
Lysozyme 0.25 mg/ml (14,000 MW)				
2,000 MWCO Hydrosart	160	6	97%	> 99%
3,000 MWCO PES	180	5	97%	> 99%
BSA 1.0 mg/ml (66,000 MW)				
5,000 MWCO PES	29	33	98%	> 99%
5,000 MWCO Hydrosart	70	14	98%	> 99%
10,000 MWCO PES	23	41	96%	> 99%
10,000 MWCO Hydrosart	35	27	98%	> 99%
30,000 MWCO PES	25	38	96%	99%
30,000 MWCO Hydrosart	20	48	96%	> 99%
50,000 MWCO PES	22	43	96%	98%
γ Globulins 1.0 mg/ml (average 160,000 MW)				
100,000 MWCO PES	54	18	96%	99%
Yeast 1.0 mg/ml (S. Cerevisiae)				
0.2 μm PES	11	86	92%	98%
Dilute solute concentration, start volume 1 litre at 3 bar, 10,000 MWCO PES				
BSA 0.001 mg/ml	18	52	90%	98%
BSA 0.01 mg/ml	20	47	92%	98%
BSA 0.1 mg/ml	21	45	94%	99%
Start volume 5 litres (two Vivaflow 200 in parallel at 3 bar) 10,000 MWCO PES				
BSA 1.0 mg/ml (66,000 MW)	67	70	97%	> 99%

Ordering Information

Vivaflow 50R modules include pressure indicator, flow restrictor and size 16 pvc peristaltic tubing and fittings	Qty per box	Prod. no.
5,000 MWCO Hydrosart	1	VF05H1
10,000 MWCO Hydrosart	1	VF05H0
30,000 MWCO Hydrosart	1	VF05H2
100,000 MWCO Hydrosart	1	VF05H4

Vivaflow 200 modules include pressure indicator, flow restrictor and size 16 pvc peristaltic tubing and fittings	Qty per box	Prod. no.
3,000 MWCO PES	1	VF20P9
5,000 MWCO PES	1	VF20P1
10,000 MWCO PES	1	VF20P0
30,000 MWCO PES	1	VF20P2
50,000 MWCO PES	1	VF20P3
100,000 MWCO PES	1	VF20P4
0.2 µm PES	1	VF20P7
2,000 MWCO Hydrosart	1	VF20H9
10,000 MWCO Hydrosart	1	VF20H0
30,000 MWCO Hydrosart	1	VF20H2
100,000 MWCO Hydrosart	1	VF20H4

Vivaflow 50R | 200 complete system comprises

Pump (240 V), Easy load pump head (size 16), tubing, 500 ml sample diafiltration reservoir	1	VFS202
Pump (115 V), Easy load pump head (size 16), tubing, 500 ml sample diafiltration reservoir	1	VFS204

Vivaflow 50R | 200 accessories

Masterflex economy drive variable speed peristaltic pump (230V)	VFP001
Masterflex economy drive variable speed peristaltic pump (115V)	VFP002
500 ml sample and or diafiltration reservoir	VFA006
Masterflex easy load pump head – size 16	VFA012
Masterflex easy load pump head – size 15 (only for operating two Vivaflow 200)	VFA013
Size 15 pvc pump tubing and Luer fittings (3 m, 4.8 × 2.6 mm)	VFA003
Size 16 pvc pump tubing and Luer fittings (3 m, 3.2 × 1.6 mm)	VFA004
Flow restrictor set (2 × 0.4, 0.6, 0.8 mm)	VFA009
Female luer fittings size 16 (10 pieces)	VFA032
Flow restrictors 0.6 mm (6 pieces)	VFA035
Female luer fittings size 15 (10 pieces)	VFA036
Flow restrictor set (2 + 0.4, 0.6, 0.8 mm)	VFA009
Female luer fittings size 16 (10 pieces)	VFA032
Flow restrictors 0.6 mm (6 pieces)	VFA035
Female luer fittings size 15 (10 pieces)	VFA036

Vivaflow 200 tubing and fittings for operation two modules

Y connector (size 15 to 2 × size 16, Luer fittings)	VFA005
Masterflex easy load pump head – size 15	VFA013

Vivaflow 50R tubing a fittings for operation of two modules

T-Connector	VFA030
-------------	--------

**Table 7: Chemical Compatibility
for Vivaflow 50R and Vivaflow 200**

Solution	PES	HY	Solution	PES	HY
Acetic acid (25%)	OK	OK	Peracetic acid (0.2%)	OK	NO
Acetone	NO	NO	Phenol (1%)	OK	NO
Ammonium hydroxide (5%)	OK	OK	Phosphate Buffer (1 M)	OK	OK
Ammonium sulfate sat.	OK	?	Pyridine	NO	NO
DMEM	OK	OK	RPMI-1640	OK	OK
Ethanol (70%)	OK	OK	Sodium azide	OK	OK
Ethyl acetate	NO	NO	Sodium deoxycholate (5%)	OK	?
Formaldehyde (30%)	OK	OK	Sodium hydroxide (1 M)	OK	OK
Formic acid (5%)	OK	OK	Sodium hydroxide (0.1 M)	OK	OK
Guanidine HCl (6 M)	OK	OK	Sodium hypochlorite (0.02%)	OK	NO
Hydrocarbons, Aromatic	NO	NO	Sodium nitrate	NO	OK
Hydrocarbons, Chlorinated	NO	NO	Sulfamic acid (5%)	OK	?
Hydrochloric acid (1 M)	OK	OK	Surfactants (0.1%)	OK	OK
Isopropanol	NO	NO	Toluene	NO	NO
Lactic acid (5%)	OK	OK	Trichloroacetic acid (10%)	NO	OK
Mercaptoethanol (10 mM)	OK	OK	Trifluoroacetic acid (10%)	OK	OK
Methanol (60%)	OK	OK	Urea (8 M)	OK	OK
n-Butanol (70%)	OK	OK			

OK = Acceptable

? = Questionable

NO = Not recommended

Sartorius Stedim Biotech GmbH
August-Spindler-Strasse 11
37079 Goettingen, Germany

Phone +49.551.308.0
Fax +49.551.308.3289
www.sartorius.com

Copyright by
Sartorius Stedim Biotech GmbH,
Goettingen, Germany.
All rights reserved. No part
of this publication may be
reprinted or translated in any
form or by any means without
the prior written permission
of Sartorius Stedim Biotech GmbH.

The status of the information,
specifications and illustrations
in this manual is indicated by the
date given below. Sartorius Stedim
Biotech GmbH reserves the right to
make changes to the technology,
features, specifications, and design
of the equipment without notice.

Status:
March 2014,
Sartorius Stedim Biotech GmbH,
Goettingen, Germany