

## μ-Plate 96 Well Square

### Instruction Manual

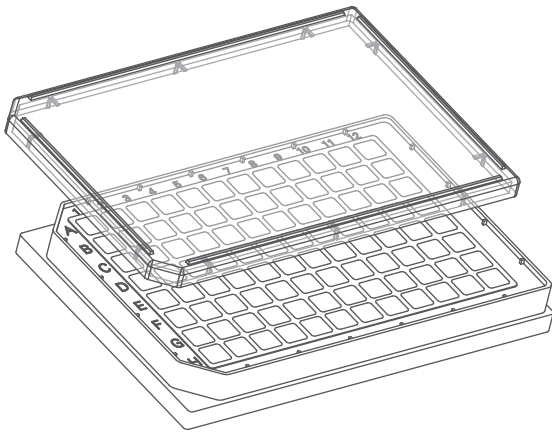

The ibidi labware comprises a variety of μ-Slides, μ-Dishes, and μ-Plates, which have all been designed for high-end microscopic analysis of fixed or living cells. The high optical quality of the ibidi Polymer Coverslip is similar to that of glass, enabling a wide range of microscopy techniques with uncompromised resolution and choice of wavelength.

The μ-Plate 96 Well Square allows you to perform high-resolution microscopy in a standard multiwell format. This imaging plate is made of black polymer material, resulting in less well-to-well crosstalk in fluorescence microscopy.

This document applies to the following products:

89626	<b>μ-Plate 96 Well Square ibiTreat</b>
89621	<b>μ-Plate 96 Well Square Untreated</b>

## Material

The μ-Plate 96 Well Square is made of a polymer that has the highest optical quality. The ibidi Polymer Coverslip bottom exhibits extremely low birefringence and autofluorescence, similar to that of glass. It is not possible to detach the bottom from the upper part. The plate is intended for one-time use and is not autoclavable, since it is only temperature-stable up to 80°C/175°F. Please note that gas exchange between the medium and the incubator's atmosphere occurs partially through the polymer coverslip, which should not be covered.

### Optical Properties of Polymer Coverslip

Refractive index (589 nm)	1.52
Abbe number	56
Thickness	No. 1.5 (180 μm)
Material	Polymer



**WARNING** – The ibidi Polymer Coverslip is compatible with certain types of immersion oil only. A list of suitable oils can be found in the Section “Immersion Oil”.

## Shipping and Storage

This product is sterilized and sealed in a gas-permeable packaging. The shelf life under proper storage conditions (in a dry place, no direct sunlight) is outlined in the following table.

Conditions	
Shipping conditions	Ambient
Storage conditions	RT (15–25°C)

Shelf Life	
ibiTreat, Untreated	36 months

## Geometry

The μ-Plate 96 Well Square provides standard geometry and numbering (A–H, 1–12).

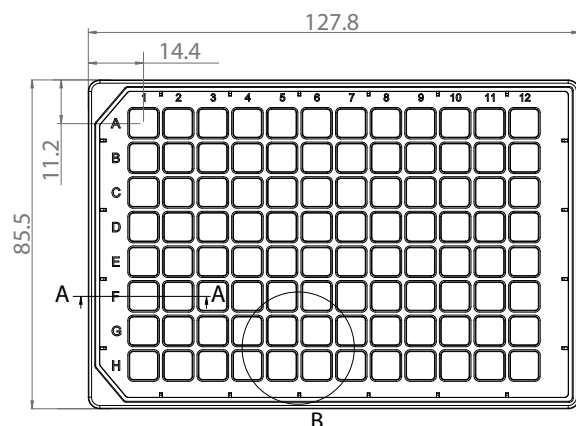

# μ-Plate 96 Well Square

## Instruction Manual

The μ-Plate 96 Well Square meets all important values of the ANSI/SLAS (SBS) Standards (1-2004, 2-2004, 3-2004 and 4-2004).

Specifications (mm)	
Length	127.8 ± 0.2
Width	85.5 ± 0.2
Height with lid	17.2 ± 0.4
Height without lid	15.0 ± 0.4
Well to well distance	9.0 ± 0.1
Well clearance	0.82 ± 0.1
Focal offset	1.0 ± 0.1

Single Well Dimensions	
Single well dimensions	7.5 × 7.5 mm
Single well depth	12.9 mm
Volume	300 μl
Growth area	0.56 cm <sup>2</sup>
Coating area using 300 μl	2.35 cm <sup>2</sup>

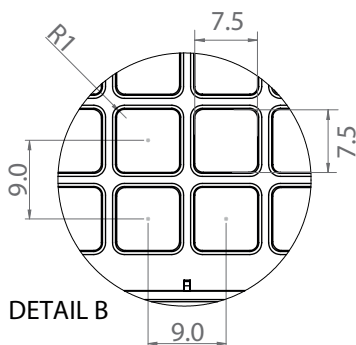
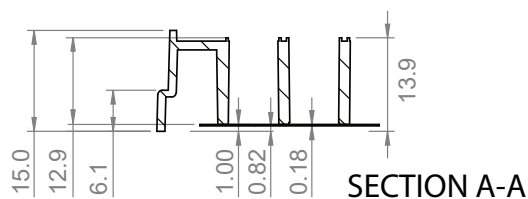

## Surface

The μ-Plate 96 Well Square is available with either an ibiTreat or an Untreated surface.

The tissue culture-treated, hydrophilic ibiTreat surface of the ibidi Polymer Coverslip is ideal for culturing adherent cells. It ensures excellent cell adhesion without the necessity for any additional coatings. Nonetheless, extracellular matrix (ECM) protein coatings can be applied to

the ibiTreat surface without any restrictions, if required.

The hydrophobic Untreated surface of the ibidi Polymer Coverslip offers weak cell adhesion unless pre-coated with an ECM protein. You can apply coatings to the Untreated surface without any restrictions. This surface is suitable for culturing adherent cells that require a specific coating.

For establishing a particular coating, we advise testing your procedure on both ibiTreat and Untreated surfaces, as proteins and biomolecules may adhere differently to hydrophilic or hydrophobic surfaces.

## Coating

Detailed information about coatings is provided in [Application Note 08: Coating Protocols for ibidi Labware](#).

In short, specific coatings are possible following this protocol:

1. Prepare your coating solution according to the manufacturer's specifications. Adjust the concentration to a coating area of 2.35 cm<sup>2</sup> and a volume of 300 μl per well.
2. Apply 300 μl per well and leave it at room temperature for at least 30 minutes.
3. Aspirate the solution and wash with the recommended protein dilution buffer.
4. The coated plate is ready to be used. Be aware that allowing the coated surface to dry out is not recommended, as some coating proteins may degrade upon drying.

### Seeding Cells

1. Trypsinize and count the cells as usual. Dilute the cell suspension to the desired concentration. Depending on your cell type, application of a  $2-5 \times 10^4$  cells/ml suspension should result in a confluent layer within 2–3 days.
2. Apply 300 μl cell suspension per well. Avoid shaking, as this will result in inhomogeneous cell distribution.
3. Cover the plate with the supplied lid. Incubate as usual (e.g., at 37 °C and 5% CO<sub>2</sub>).

Insensitive cells can be left in their seeding medium for several days and grow to confluence there. However, optimal results might be achieved when the medium is changed every 2–3 days. For this, carefully aspirate the old medium and replace it by 300 μl fresh medium per well.



**TIP** – You can stack the μ-Plates to save space in your incubator. This will not affect cell growth. Due to stability reasons, we recommend making batches with not more than 6 plates.

### Microscopy

To image your cells, no special preparations are necessary. Living or fixed cells can be directly observed, preferably on an inverted microscope. The bottom cannot be removed. For optimal results in fluorescence microscopy and for storage of fixed and stained samples, ibidi provides mounting media that are optimized for ibidi lab-ware:

Cat. No. 50001: [ibidi Mounting Medium](#)

Cat. No. 50011: [ibidi Mounting Medium with DAPI](#)

### Chemical Compatibility

The following table provides some basic information on the chemical and solvent compatibility of the μ-Plate 96 Well Square. For a full list of compatible solvents and more information on chemical compatibility, visit [ibidi.com/chemicals](https://www.ibidi.com/chemicals).

Chemical / Solvent	Compatibility
Methanol	Yes
Ethanol	Yes
Formaldehyde	Yes
Acetone	Yes, without lid
Mineral oil	No
Silicone oil	Yes
Immersion oil	See Section “Immersion Oil”

### Immersion Oil



**WARNING** – When using oil immersion objectives with the ibidi Polymer Coverslip, use only the immersion oils specified in the table below. The use of any non-recommended oil could damage the ibidi Polymer Coverslip. The resulting leakage may harm objectives and microscope components. All immersion oils that are not listed in the table below should be considered non-compatible.

Company	Product	Ordering No.	Lot Number	Test Date
ibidi	ibidi Immersion Oil 2	50102	24-07-04	07/2024
Cargille	Type A	16482	100592	01/2017
Cargille	Type HF	16245	92192	01/2017
Carl Roth	Immersion oil	X899.1	414220338	01/2017
Leica	Immersion Liquid	11513859	n.a.	03/2023
Leica	Immersion Liquid Type G	11513910	n.a.	04/2024
Nikon	Immersion Oil F2 30cc	MXA22192	n.a.	01/2020
Nikon	Silicone Immersion Oil 30cc	MXA22179	20191101	01/2020
Olympus	Silicone Immersion Oil	SIL300CS-30CC	N4190800	01/2017
Zeiss	Immersionol 518 F	444960-0000	220211	03/2023
Zeiss	Immersionol 518 F (30 °C)	444970-9010	220816	03/2023
Zeiss	Immersionol 518 F (37 °C)	444970-9000	220302	03/2023
Zeiss	Immersionol W 2010	444969-0000	101122	04/2012
Zeiss	Immersionol Sil 406	444971-9000	80730	03/2023
Zeiss	Immersionol G	462959-9901	211117	03/2023

### For research use only!

Further information can be found at [ibidi.com](https://www.ibidi.com). For questions and suggestions, please contact us by e-mail at [info@ibidi.com](mailto:info@ibidi.com) or by telephone at +49 (0)89/520 4617 0.

© ibidi GmbH, Lochhamer Schlag 11, 82166 Gräfelfing, Germany.